

Medical Refrigerator and Freezer Instruction Manual

Applicable models:

**KYC060G KYD060F
KYC110G KYD110F
KYC140G KYD260F
KYC260G KYD390F
KYC390G KYD600F
KYC600G**

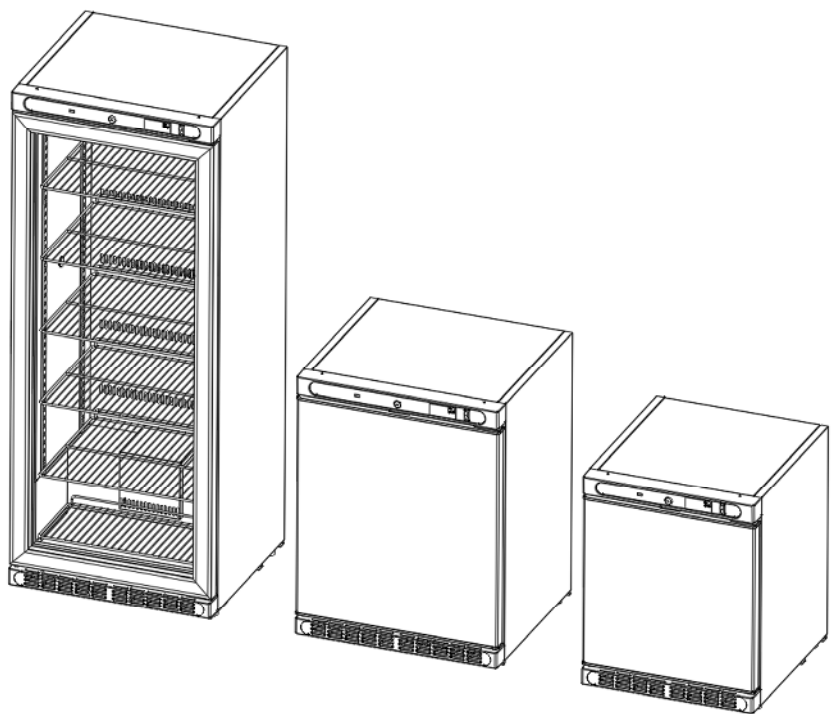

For Technical Service, contact

Qingdao Carebios Biological Technology Co.,Ltd.
No.433-5 Sancheng Road, Lancun Town, Jimo District,
Qingdao, 266000, China
Tel 0086 400 118 362 6
info@carebios.com

Dear Customer:

Congratulations on your purchase of this product. Like all of our products, this product has also been developed on the basis of the latest technology and produced using reliable and modern electrical components.

Please take a few minutes before starting operation of the appliance and read the following operating instructions. Save this manual for further reference.

Many thanks.



CAUTION!

All internal adjustments and maintenance must be performed by qualified service personnel.

This appliance can be used by children aged from 8 years and above and persons with reduced physical, sensory or mental capabilities or lack of experience and knowledge if they have been given supervision or instruction concerning use of the appliance in a safe way and understand the hazards involved.

Children shall not play with the appliance.

Cleaning and user maintenance shall not be made by children without supervision.



Environmental Protection

Discarded electric appliances are recyclable and should not be discarded in the domestic waste! Please actively support us in conserving resources and protecting the environment by returning this appliance to the collection centers(if available).



Important operating and/or maintenance instructions. Read the accompanying text carefully.



Potential electrical hazards. Only qualified persons should perform procedures associated with this



Hot surface(s) present which may cause burns to unprotected skin or to materials which may be damaged by elevate



**Extreme temperature hazards, hot or cold.
Use special handling equipment or wear**

Always use the proper protective equipment (clothing,gloves,etc.)

Always use dissipate extreme cold or heat and wear protective clothing.

Always follow good hygiene practices.

Each individual is responsible for his or her own safety.

Table of Contents

1. Installation.....	1
1.1 Safety Information.....	1
1.2 Assembly.....	2
1.3 Positioning the Medical Refrigerator.....	2
1.4 Ventilation.....	3
1.5 Power Supply.....	3
2. Product description.....	4
3. Operation.....	5
3.1 Access to power.....	5
3.2 Setting Temperature.....	5
3.3 Turn on/off the light.....	5
4. Cleaning.....	5
4.1 Out of service.....	5
5. Maintenance.....	6
6. Disposal.....	6

If the user's manual is lost or damaged, you can through our website to download or contact us by E-mail.

1.Installation

1.1 Safety Information

All electrical work must be executed by suitably qualified persons. When using any electrical appliance, safety precautions must always be observed.

- ⊍ Do not use this appliance for other than its intended use. This product is intended for use as a beverage Medical Refrigerator. Consult your supplier for alternatives.
- ⊍ Do not cover the front grille or block the rear air entry by placing object up against the cabinet.
- ⊍ Please close attention, when used by or near children, infirm persons.
- ⊍ Ensure adequate ventilation.
- ⊍ Do not probe any openings.
- ⊍ Do not touch any moving parts or hot surfaces.
- ⊍ Regulations require that all electrical work be carried out by authorized persons. For your own safety and that of others please ensure this is done.
- ⊍ Do not overload the power supply. Always ensure on the rating label. The rating label is located.

If have any problem, please consult a qualified electrician. Caution: Never use extension leads or multiple adaptors.

- ⊍ If the mains supply cord is damaged, it must be replaced by the manufacturer, its service agent or similarly qualified and skilled persons in order to avoid hazard.
- ⊍ Disconnect the mains power supply before attempting any cleaning, removal of any covers, or maintenance work.
- ⊍ Do not store explosive substances, such as aerosol cans with flammable propellant.
- ⊍ Warning: Do not use mechanical devices or other means to accelerate the defrosting process. Defrosting is performed automatically.
- ⊍ Warning: Do not damage the refrigeration circuit.
- ⊍ Warning: Do not use electrical appliances inside the storage compartment of this appliance.

1.2 Assembly

- u Remove the appliance from the packaging and peel off any protective film from all surfaces.
- u Fit the shelf support clips onto the shelf support strips, making sure that the clips for each shelf are of the same height and that they are securely engaged on the support strip.
- u Unwrapping each shelf carefully, to prevent damaging their protective coating or surface finish.
- u Position the shelves onto the clips.



Please dispose of all waste packaging appropriately and in accordance with all local recycling laws.



WARNING

Do not overload the power supply. Always ensure that the power supply is adequate for the electrical requirements specified on the rating label and never use extension leads or multiple adaptors.

1.3 Positioning the Medical Refrigerator

- u Please position the cabinet carefully being careful not to bump it.
- u The power supply flex exits the Medical Refrigerator at the bottom right hand side (as viewed from the front). For ease of access; the flex should be retrieved prior to positioning the Medical Refrigerator in its final location.
- u The maximum recommended ambient temperature for this Medical Refrigerator is 38°C
- u Avoid positioning the appliance in direct sunlight or damp areas.
- u Allow adequate space for the door(s) to fully open.
- u Ensure that this Medical Refrigerator is positioned on a level surface, so as to allow the door(s) to shut and seal correctly, as well as to allow proper drainage from the evaporator tray, to prevent any overflow. If necessary, adjust the screw feet of the appliance to make it level.

Note: If the unit has not been stored or moved in an upright position, let it stand upright for approximately 12 hours before operation.

1.4 Ventilation

- u All models must have clear and unobstructed ventilation from the entire surface area of the front grille.
- u The 2 and 3 door models may be built into an enclosure without the need for ventilation other than at the front.
- u The single door of Medical Refrigerators must have a minimum ventilation space of 20mm at sides and rear.

- u **WARNING:**  Failure to provide the minimum ventilation space will harm the performance of your Medical Refrigerator could cause fire and will invalidate the warranty.

- u **WARNING:**  Keep clear of obstruction all ventilation openings in the appliance enclosure or in the structure for building in.

1.5 Power Supply

The Medical Refrigerator uses a three-pin plug which must be well grounded. Never ground the Medical Refrigerator through a gas pipe, tap water pipe OR the grounded wire of single-phase power supply etc. Never share same circuit with other appliances. Before plugging in your Medical Refrigerator for the first time make sure the power cable is free from damage and check that your voltage corresponds to that on the serial plate.

Once plugged in the display will show the temperature inside the Medical Refrigerator and the compressor will run late on (the indicator light of cooling will be on at the same time). This temperature is the actual temperature recorded by the probes inside the Medical Refrigerator and as the fridge cools to the set point (factory set at 4°C/39°F) so the number on the display will descend accordingly. If power is cut off, wait for at least 5 minutes before plugging the unit in again to avoid damaging the compressor.

2.Product description

Refrigerator

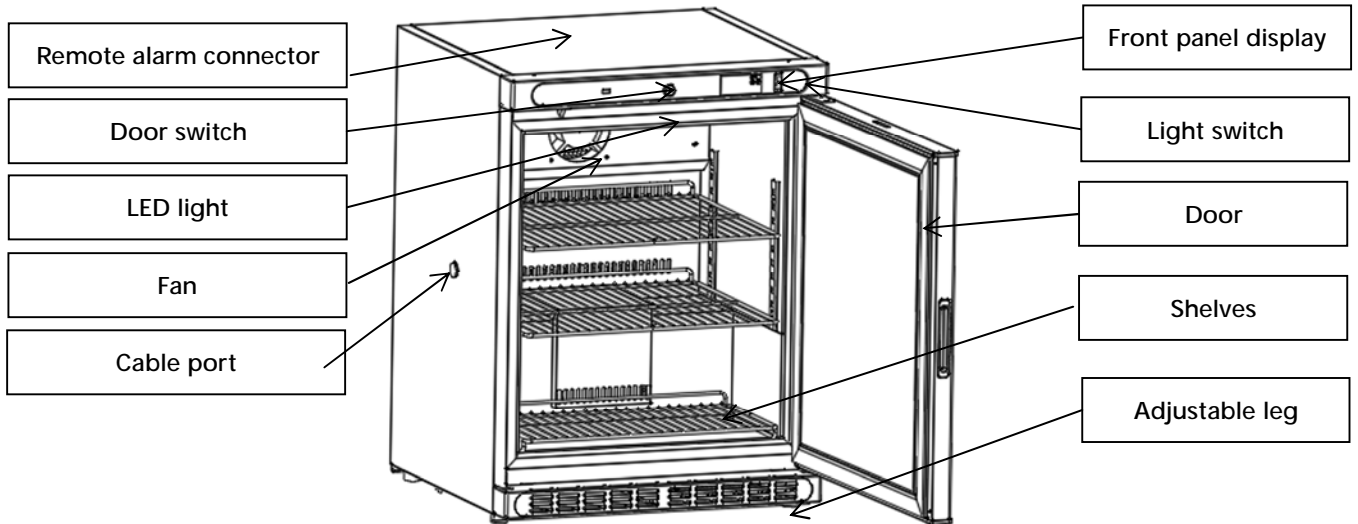

Freezer

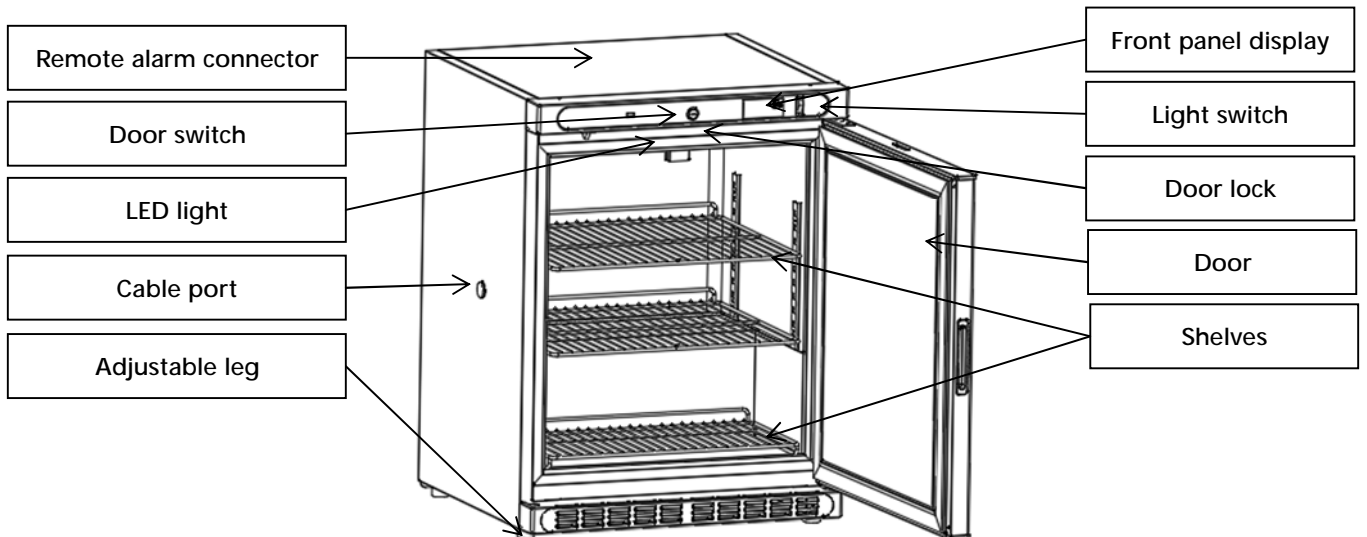

3. Operation

This product is designed to operate at a recommended ambient temperature not more than 38°C.

3.1 Access to power

- u Close the door of the appliance.

3.2 Setting Temperature

- u Press down to decrease the set temperature.
- u Press up to increase the set temperature.

3.3 Turn on/off the light

- u The light will turn on while the door is opened and will turn off while the closed.
- u If you want to turn on the light while you do not open the door, you can turn on the switch.

4. Cleaning

- u **WARNING:**  You must disconnect the plug before cleaning or maintenance.
- u Do not use abrasive cleaning agents which may scratch and harm the delicate interior finishes of your appliance.
- u Always wipe dry after cleaning.
- u An agent or qualified technician must carry out repair if required.
- u When cleaning the storage box, please use a soft cloth or sponge dipped in warm water (neutral detergent can be added) to clean the storage box.
- u It is strictly forbidden to spray and wash with water to avoid affecting the electrical insulation performance.
- u It is strictly prohibited to use hard brush, wire brush, detergent, gasoline, banana water, acetone and other organic solvents, hot water or acid, alkali, etc. to clean the storage box.

4.1 Out of service

- u If the storage box is out of service for a long time, the power supply should be cut off and cleaned according to the above method, and the door should be opened to dry.
- u In general, it is not necessary to stop using the storage box for a long time in order to avoid affecting the service life.

5. Maintenance

If your appliance develops a fault, please check the following table before making a call to the helpline.

Fault	Possible Cause	Action
The appliance is not working	The unit is plugged in correctly	Check the unit is plugged in correctly
	Plug or lead is damaged	Call Our agent or qualified technician
	Power supply	Check power supply
	Internal wiring fault	Call Our agent or qualified technician
The appliance turns on, but the temperature is too high or too low	Filter or condenser blocked with dust	Clean filter or condenser
	Doors are not shut properly	Check doors are shut and seal are not damaged
	Appliance is located near a heat source or air flow to the condenser is being interrupted	Move the appliance to a more suitable location
	Ambient temperature is too high	Increase ventilation or move appliance to a Medical Refrigerator position
	Insufficient airflow to the fans	Remove any blockages to the fans
	Appliance is overloaded	Reduce the amount stored in the appliance
	Factory default parameters adjusted	Call Our agent or qualified technician
The LED lights not working	Led light short Leaded damage	Call Our agent or qualified technician
The appliance appear BT alarm	See description below	See description below
The appliance is unusually loud	The appliance is touching a neighboring object	Check installation position and change if necessary
	The appliance has not been installed in a level or stable position	Check installation position and change if necessary

6. Disposal

If in any doubt, please consult your Local Authority, contact us or contact the reseller from whom you purchased the appliance.